

TOKU 



# CONSTRUCTION & INDUSTRIAL TOOLS

Ver 2.02

**TOKU PNEUMATIC CO., LTD.**  
[www.toku-net.co.jp/en](http://www.toku-net.co.jp/en)

# NEEDLE SCALERS & FLUX CHIPPERS

## N TFC FEATURES

- Compact and lightweight body for comfortable operation
- Effective in removing old paint and rust in difficult corners
- Simple valve design for precise throttle control
- Weld flux chipper can be converted into needle scaler by adding needle scaler attachment (each 200 series and 300 series)
- 5/64" (3mm) dia. needles as standard for N-200 and 1/8" (2mm) needles is also available for N-200



**N-200**



**TFC-200**



**TFC-300H**



**TN-300H**

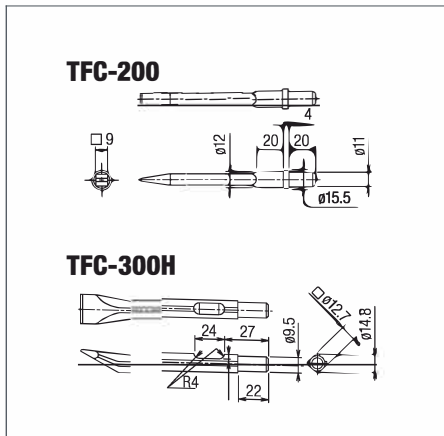

## SPECIFICATION

MODEL	BORE inch (mm)	STROKE inch (mm)	IMPACT RATE B.P.M.	NEEDLE DIA.x LENGTHxQ'TY inch (mm)	WEIGHT lb (kg)	LENGTH inch (mm)	AIR CONSUMPTION CFM (m <sup>3</sup> /min)	AIR INLET inch
N-200	3/4(20)	1/2(12)	12,000	1/8x4-7/8x12pcs(3x125x12pcs)	2(1.1)	8-7/8(225)	09(0.25)	1/4NPT
TN-300H	1(25.4)	1-1/2(39)	4,500	1/8x7x19pcs(3x180x19pcs)	9(4.3)	22-1/2(571)	18(0.5)	3/8NPT

MODEL	BORE inch (mm)	STROKE inch (mm)	IMPACT RATE B.P.M.	WEIGHT lb (kg)	LENGTH inch (mm)	AIR CONSUMPTION CFM (m <sup>3</sup> /min)	AIR INLET inch	HOSE SIZE inch (mm)
TFC-200	3/4(20)	1/2(12)	12,000	2(0.9)	7-1/4(182)	9(0.25)	1/4NPT	1/4(6.3)
TFC-300H	1(25.4)	1-1/2(39)	4,500	9(4.3)	22-1/2(571)	18(0.5)	3/8NPT	1/2(12.7)

Dynamic pressure: 90 PSI (0.6MPa) for all products